



Safety is for life.™

PRODUCT INFORMATION



ECONOMIC ISOLATION OF RAW GAS LINES TO FILTERS AND DUST COLLECTORS

Applications

In the event of an explosion, the Q-Flap RX™ explosion isolation flap valve effectively isolates plant components in almost all industrial sectors. The Q-Flap RX™ is also perfectly suited for the aspiration lines of filtering dust collectors, and for the suction intake lines of mills.

The nominal pipe sizes up to DN 400 are primarily used for decentralised extraction systems in the pharmaceutical and chemical industries, whereas nominal pipe sizes between DN 450 and DN 710 are also used for centralised dust extractors in the grain and food industry. Nominal pipe sizes from DN 800 to DN 1250 are used in the wood and heavy industry.

In order to meet the highly diverse requirements for the individual industries, the Q-Flap RX™ product range offers three different design versions. The nominal pipe sizes up to DN 710 feature an inspection flap, and the larger nominal pipe sizes have a modular design. This ensures that a maintenance and servicing of any pipe size can be carried out easily.

Your advantages

- **Quick maintenance without the need for a complete dismantling of the device**, simply by completely opening the inspection flap on pipe sizes up to DN 710.
- **Optionally: longer maintenance intervals** by integrating a supervision function.
- **Flexible use:** The Q-Flap RX™ is available for all common nominal pipe sizes up to DN 1250.

Made in Germany

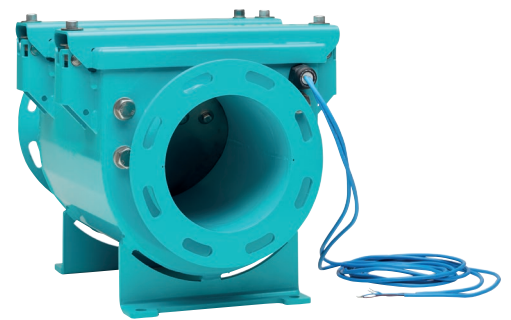

Mechanism (DN 140 to DN 710)

Basic position



When the system is shut down, the valve blade rests in an inclined position.

In operation

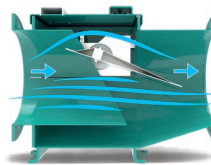

During normal operation, the explosion isolation flap valve is kept open by the air flow of the system.

In case of an explosion



In the event of an explosion, the valve blade is closed by the pressure wave of the explosion.



Meets the requirements of NFPA 69 (Option)

You can find detailed information and contact details for enquiries relating to Q-Flap RX™ at www.rembe.de. Give us a call on: T +49 2961 7405-0 or contact us via email: info@rembe.de





Safety is for life.™

PRODUCT INFORMATION

Technical data DN 140 to DN 400*

Diameter nominal		140	160	200	250	280	315	355	400
Dimensions [mm]	Length L	420	440	440	590	620	620	620	620
	Width W	314	334	374	466	496	531	571	616
	Height H	324	335	372	468	497	532	574	619
	Pivoting range S	230	251	291	369	398	434	473	518
	LK - Ø	182	200	241	292	332	366	405	448
	nxM	8xM10	8xM10	8xM10	8xM10	8xM10	8xM10	8xM10	12xM10
Weight	kg	21	22	23	48	55	59	65	71
Dust explosion class		St1 and St2							
Max. K_{st} value	bar x m/s	300				230			
Max. reduced explosion overpressure (Max. P_{red}) in the vessel	bar g	1.9				1.5			
Explosion pressure resistance of the explosion isolation flap valve	bar g	3.4				2.0			
Min. protected volume	m ³					4.4			
Min. mounting distance with St1	m					2.5			
Max. mounting distance with St1	m	8.0				7.0			
Min. protected volume (only valid for $K_{st} \leq 230$)	m ³					1.0			
Min. mounting distance with St2	m	1.0				3.5			
Max. mounting distance with St2	m	8.0				3.5			

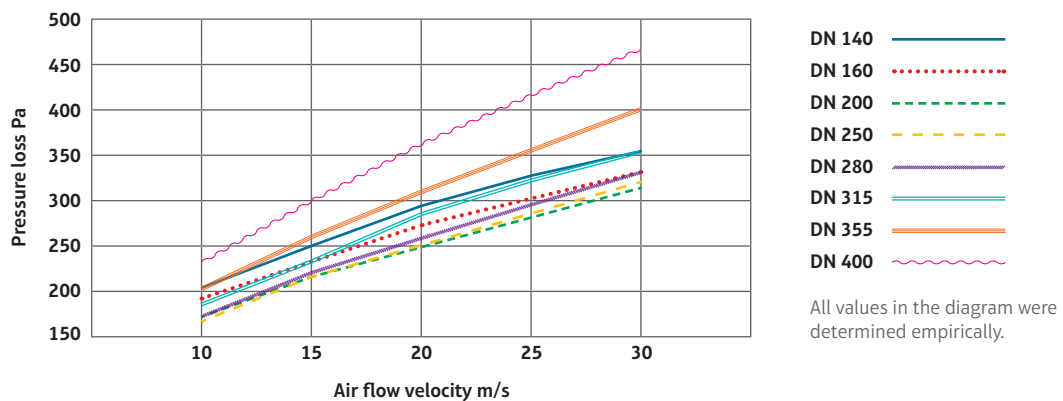
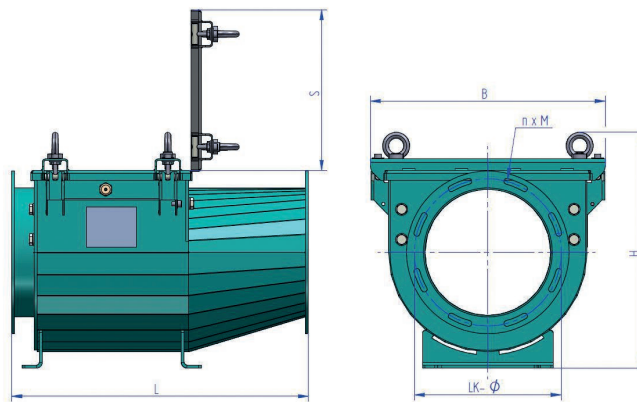

*Our specialists will gladly consult you personally in case of deviating operating conditions.



Technical data DN 450 to DN 710**

Diameter nominal		450	500	560	630	710
Dimensions [mm]	Length L	661	714	796	826	856
	Width W	642	707	772	837	902
	Height H	635	700	760	845	925
	Pivoting range S	303	323	363	393	422
	LK - Ø	497	551	629	698	775
	nxM	12xM10	12xM10	16xM12	16xM12	16xM12
Weight	kg	90	100	120	140	150
Dust explosion class		St1 and St2				
Max. K_{st} value	bar × m/s	250				
Max. reduced explosion overpressure (Max. p_{red}) in the vessel	bar g	0.95	0.77			
Explosion pressure resistance of the explosion isolation flap valve	bar g	1.46	1.03			
Min. protected volume	m ³	0.7	2.77			
Min. mounting distance	m				3.5	
Max. mounting distance	m				9.5	

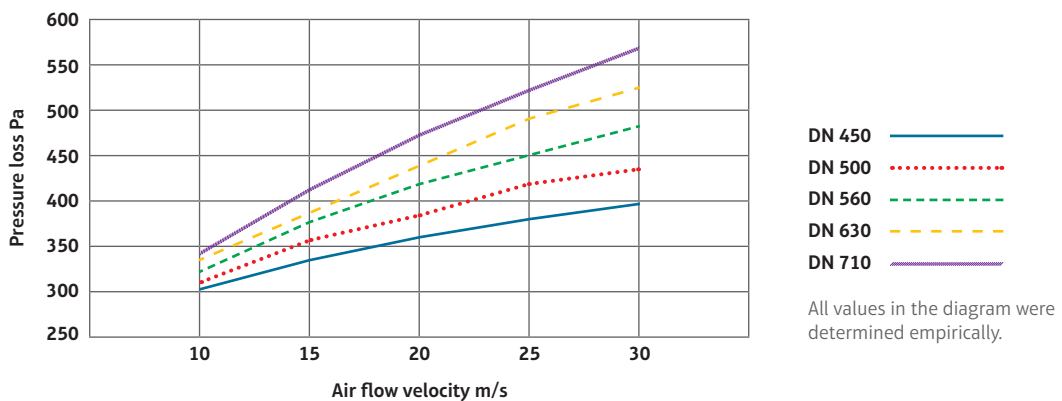
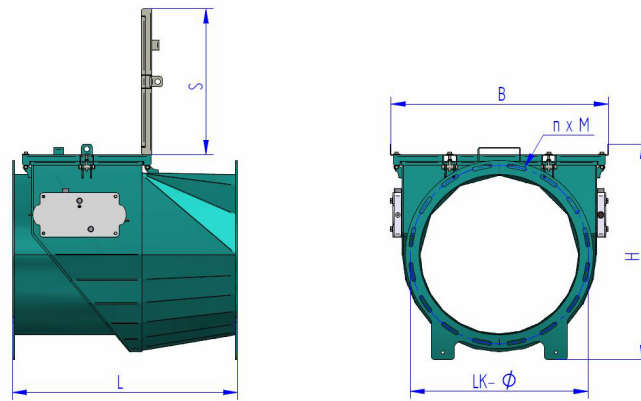

*Our specialists will gladly consult you personally in case of deviating operating conditions.



Safety is for life.™

PRODUCT INFORMATION

Technical data DN 800 to DN 1250*

Diameter nominal		800	900	1000	1120	1250
Dimensions [mm]	Length L	1303	1413	1551	O. r.**	O. r.**
	Width W	1105	1245	1375	O. r.**	O. r.**
	Height H	1105	1245	1375	O. r.**	O. r.**
	Pivoting range S	–	–	–	O. r.**	O. r.**
	LK - Ø	861	958	1067	O. r.**	O. r.**
	nxM	24xM12	24xM12	24xM12	O. r.**	O. r.**
Weight	kg	266	350	462	O. r.**	O. r.**
Dust explosion class		St1 and St2			O. r.**	O. r.**
Max. K _{St} value	bar × m/s	265			O. r.**	O. r.**
Max. reduced explosion overpressure (Max. p _{red}) in the vessel	bar g	0.95	0.92		O. r.**	O. r.**
Explosion pressure resistance of the explosion isolation flap valve	bar g	0.99	1.09		O. r.**	O. r.**
Min. protected volume	m ³	2.77			O. r.**	O. r.**
Min. mounting distance	m	3.2			O. r.**	O. r.**
Min. mounting distance	m	9.2			O. r.**	O. r.**

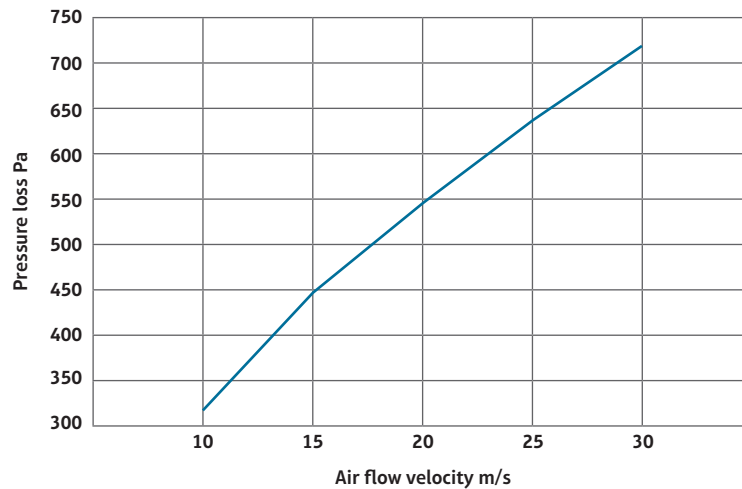
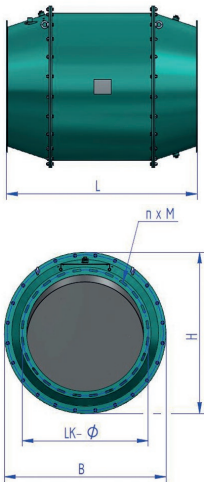

DN 800 —————
DN 900 O. r.**
DN 1000 O. r.**
DN 1120 O. r.**
DN 1250 O. r.**

All values in the diagram were determined empirically.

Technical data*

Type	Q-Flap RX™ with switches O. r.**	Q-Flap RX™ in stainless steel O. r.**
Certification	EU Directive 2014/34/EU (ATEX 114) and NFPA conform**	
Mounting position	Horizontal, suction side (fan after flap "pull flow")	
Operating air flow velocity	12 to 35 m/s	
Operating temperature	-20 to +80 °C (+100 °C without switch)	
Material	Housing: carbon steel valve blade: stainless steel	
Raw gas dust concentration	DN 140 to DN 710: max. 100 g/m ³	DN 800 to DN 1000: max. 250 g/m ³
Paint	RAL Design 190 60 45	

*Our specialists will gladly consult you personally in case of deviating operating conditions.

**On request

Consulting. Engineering. Products. Service.

REMBE® GmbH Safety+Control

Gallbergweg 21 | 59929 Brilon, Germany | T +49 2961 7405-0 | F +49 2961 50714
info@rembe.de | www.rembe.de