



ADD-ON MODULE FOR EXPLOSION VENTS TO REDUCE THE SIZE OF ENDANGERED AREAS

TARGO-VENT limits the opening angle of an explosion vent in order to protect people, vehicles or subsequently erected buildings. By decreasing the size of endangered areas, TARGO-VENT helps you to reduce your safety areas to a minimum and increase usable operating space while providing optimum protection against explosions.

Applications

Ideal for rectangular explosion vents,

- that vent into areas used by vehicles or pedestrians,
- used in outdoor applications,
- that vent into previously clear areas, which have subsequently been built upon.

Mechanism

TARGO-VENT limits the opening angle of the explosion vent and guides the explosion pressure wave, flames and heat into defined areas. This minimises the size of the safety areas required.

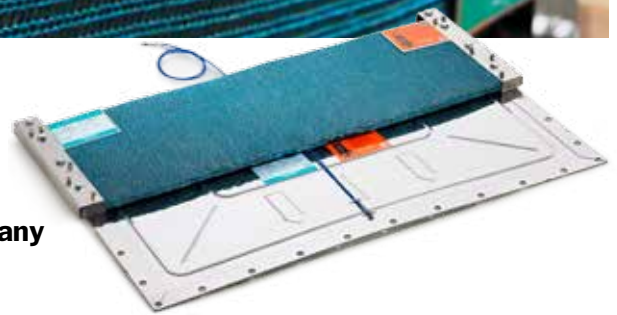

Made in Germany

Your advantages

- Smaller safety areas required in front of vent openings – **more productive use of valuable operating areas.**
- **Smaller area required** for explosion venting than with alternative deflectors.
- **Low cost protection** of infrastructure.
- **Safes traffic routes for people and vehicles** while simultaneously reducing the safety area required.
- Retrofitting with TARGO-VENT provides **greater safety for existing installations.**
- **Maintenance-free and long service life** through the use of stainless steel.



ATEX
EC type examination
certificate no.
FSA 13 ATEX 1637



Safety is for life.™

PRODUCT INFORMATION

Technical data

Valid for explosion vents with a venting area of $\leq 0.54 \text{ m}^2$

Max. K_{St} Value	$\leq 200 \text{ bar} \times \text{m/s}$				
Max. red. explosion pressure P_{red}	$\leq 1.0 \text{ bar}$ at 22 °C				
P_{red}	0.2 bar	0.4 bar	0.6 bar	0.8 bar	1.0 bar
Deflection angle	45°	45°	40°	35°	25°
Venting efficiency	55%	60%	62%	65%	70%

Valid for explosion vents with a venting area of between 0.54 m^2 and 1.1 m^2

Max. K_{St} -Wert	$\leq 200 \text{ bar} \times \text{m/s}$		
Max. red. explosion pressure P_{red}	$\leq 0.4 \text{ bar}$ at 22 °C		
P_{red}	0.2 bar	0.3 bar	0.4 bar
Deflection angle	45°	45°	40°
Venting efficiency	55%	58%	60%

Note: Linear relationship between the specified response pressure, deflection angle and efficiency.

Dimensions and weight

Measurements [mm]	Approx. weight [kg]
305 × 610	3
620 × 820	9
586 × 920	9
610 × 1118	10
920 × 920	14
915 × 1118	15

Other sizes available on request.

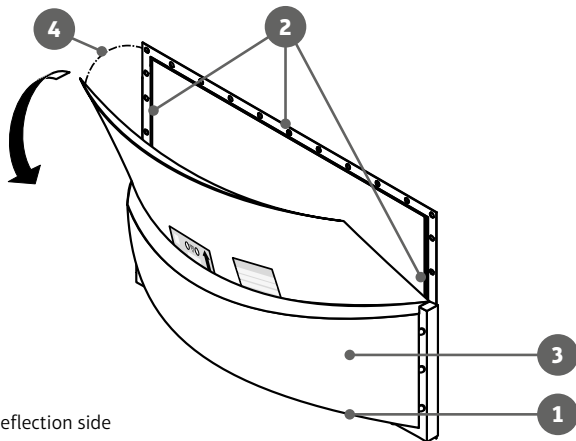

- 1 Deflection side
- 2 Opening sides
- 3 TARGO-VENT
- 4 Max. opening angle



With TARGO-VENT: The flame is deflected into safe areas.



Without TARGO-VENT: The flame endangers operating areas.

Consulting. Engineering. Products. Service.

REMBE® GmbH Safety+Control

Gallbergweg 21 | 59929 Brilon, Germany | T +49 2961 7405-0 | F +49 2961 50714
info@rembe.de | www.rembe.de